

Cardiac output estimation using pulse wave analysis—physiology, algorithms, and technologies: a narrative review

Bernd Saugel^{1,2,*†}, Karim Kouz^{1,†}, Thomas W. L. Scheeren³, Gillis Greiwe¹, Phillip Hoppe¹, Stefano Romagnoli^{4,5} and Daniel de Backer⁶

¹Department of Anesthesiology, Center of Anesthesiology and Intensive Care Medicine, University Medical Center Hamburg-Eppendorf, Hamburg, Germany, ²Outcomes Research Consortium, Cleveland, OH, USA, ³Department of Anesthesiology, University of Groningen, University Medical Center Groningen, Groningen, The Netherlands, ⁴Department of Health Science, Section of Anesthesia and Critical Care, University of Florence, Florence, Italy, ⁵Department of Anesthesia and Critical Care, Careggi University Hospital, Florence, Italy and ⁶Department of Intensive Care, CHIREC Hospitals, Université Libre de Bruxelles, Brussels, Belgium

*Corresponding author. E-mail: bernd.saugel@gmx.de

†These authors contributed equally.

Summary

Pulse wave analysis (PWA) allows estimation of cardiac output (CO) based on continuous analysis of the arterial blood pressure (AP) waveform. We describe the physiology of the AP waveform, basic principles of PWA algorithms for CO estimation, and PWA technologies available for clinical practice. The AP waveform is a complex physiological signal that is determined by interplay of left ventricular stroke volume, systemic vascular resistance, and vascular compliance. Numerous PWA algorithms are available to estimate CO, including Windkessel models, long time interval or multi-beat analysis, pulse power analysis, or the pressure recording analytical method. Invasive, minimally-invasive, and noninvasive PWA monitoring systems can be classified according to the method they use to calibrate estimated CO values in externally calibrated systems, internally calibrated systems, and uncalibrated systems.

Keywords: arterial pressure; cardiovascular dynamics; haemodynamic monitoring; monitor; pulse contour analysis; stroke volume

Editor's key points

- Pulse wave analysis allows estimation of cardiac output based on continuous analysis of the arterial blood pressure waveform, a complex physiological signal determined by an interplay of left ventricular stroke volume, systemic vascular resistance, and vascular compliance.
- There are invasive, minimally-invasive, and noninvasive pulse wave analysis monitoring systems.
- The systems can be classified according to the method used to calibrate the estimated cardiac output values in

externally calibrated systems, internally calibrated systems, and uncalibrated systems.

Cardiac output (CO), the product of stroke volume (SV) and heart rate, is a key determinant of oxygen delivery.¹ Optimising CO using perioperative goal-directed haemodynamic therapy improves patient-centred postoperative outcomes in high-risk patients having major surgery.^{2,3} CO monitoring, in addition to echocardiography, is also recommended in critically ill patients with complex circulatory shock to diagnose the type of shock and to monitor responses to therapeutic interventions.^{4,5}

Accepted: 10 September 2020

© 2020 British Journal of Anaesthesia. Published by Elsevier Ltd. All rights reserved.
For Permissions, please email: permissions@elsevier.com

There are numerous methods to measure or estimate CO in perioperative and intensive care medicine^{6–8}; one method is pulse wave analysis (PWA) (i.e. the continuous analysis of the arterial blood pressure [AP] waveform).^{7,9,10} The AP waveform can be recorded invasively with an arterial catheter or non-invasively with innovative sensors.^{6–8} PWA is used to estimate CO during perioperative goal-directed haemodynamic therapy,^{9,11–13} and to assess fluid responsiveness during a passive leg raising test¹⁴ or a fluid challenge manoeuvre.¹⁵ A profound understanding of basic measurement principles and limitations is key when using PWA in clinical practice.

In this article, we describe and discuss the physiology of the AP waveform, basic principles of PWA algorithms for CO estimation, and PWA systems available for clinical practice.

Physiology of the arterial pressure waveform

Blood flow is determined by the pressure difference between the two ends of a vessel and vascular resistance.¹⁶ The relationship between those three variables—blood flow, AP, and vascular resistance—can be described by Darcy's law that is an analogy to Ohm's law (Fig. 1).¹⁶ During systole, blood is ejected from the left ventricle into the aorta (i.e. left ventricular SV).¹⁷ Left ventricular SV together with the compliance of the aorta mainly determine systolic AP (SAP). Diastolic AP (DAP) is primarily determined by left ventricular relaxation and systemic vascular resistance—with the latter regulating blood flow through peripheral vessels.¹⁷ Pulse pressure (PP) is the difference between SAP and DAP and closely related to SV. Mean AP (MAP) is not the arithmetic mean of SAP and DAP but rather the average pressure over one cardiac cycle.¹⁸

The resistance to blood flow by the systemic circulation is called systemic vascular resistance or total peripheral resistance and is mainly determined by the vascular tone of small vessels—especially arterioles—that have the ability to contract.¹⁶ Based on Poiseuille's law, vascular resistance of a vessel is mainly determined by the radius of the blood vessel (Fig. 1). The vessel radius is highly regulated by various mechanisms such as the sympathetic nervous system, blood flow autoregulation, and local humoral factors.¹⁹ Vascular resistance and systemic vascular resistance cannot be

measured directly, but must be derived from blood flow and the pressure difference between two points within the vasculature.

Vascular compliance—also referred to as vascular capacitance—is the ability of a vessel to distend with increasing transmural pressure.²⁰ The compliant properties of the aorta and other elastic arteries ensure blood flow during diastole that would otherwise only occur during systole.²⁰ Changes in the compliant properties—such as in arteriosclerosis—lead to a more pulsatile flow and pressure during the cardiac cycle. This may cause mechanical tissue damage as a result of high PP amplitudes.²¹

The AP waveform consists of multiple forward ejected and reflected waves and therefore gets progressively distorted.²² This distortion can be observed by continuous changes of the AP waveform during its movement along the arterial tree into the periphery (Fig. 1).²² Reflection phenomena occur at multiple sites along the arterial tree because of changes in arterial properties or vessel architecture.²¹ At the aortic root, the AP waveform is characterised by a sharp upstroke, a slow rise to peak, the dicrotic notch, and an exponential diastolic decline.²⁰ As the AP waveform moves along large elastic and smaller conduit arteries, the PP is amplified because of decreasing compliance of the conducting vessels and wave reflection phenomena. Since PP amplification does not require additional energy input in the arterial system, it is more a distortion rather than a true amplification, and MAP remains almost unchanged. It is thus important to recognise that the peripherally measured PP overestimates the central PP, and that age and other factors may affect this relationship, mostly by affecting wave reflection phenomena.²³

When the AP waveform reaches smaller arteries, arterioles, and capillaries, PP becomes progressively lower.²⁰ This peripheral decrease in PP is called damping and is mainly determined by changes in the vascular resistance and compliance of these smaller vessels.

In summary, the complex interplay of left ventricular SV, vascular compliance, and systemic vascular resistance and other physiological and physical factors results in the AP waveform—a complex physiological signal (Fig. 2).

Pulse wave analysis for blood flow estimation—basic measurement principles

The term PWA comprises numerous algorithms to measure or estimate CO from the AP waveform. Here, we give an overview of basic principles of PWA algorithms and their underlying physiologic assumptions.

Windkessel models

Two-element Windkessel

The first attempts to estimate SV and CO using PWA were based on the Windkessel model of Otto Frank.²⁴ This model assumes that at steady haemodynamic state, the amount of blood entering a blood vessel is equal to the amount of blood leaving the vessel during the cardiac cycle. The compliance of downstream vessels directly affects the flow through them in a predictable way. During systole, a certain amount of mechanical energy is used to expand elastic vessels (especially the aorta) that hold some of the blood that otherwise would pass through them. Consequently, during systole, the outflow of the aorta is lower than the inflow. Physically, elastic vessels

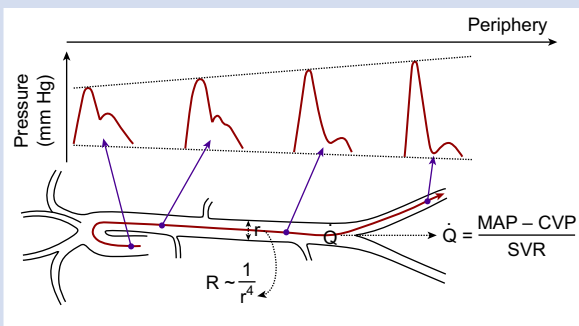

Fig 1. Arterial blood pressure waveforms at different locations along the arterial tree. Blood flow (Q) is determined by the pressure difference between mean arterial blood pressure (MAP) and central venous pressure (CVP), and the systemic vascular resistance (SVR). Vascular resistance (R) of a vessel is mainly determined by vessel radius (r).

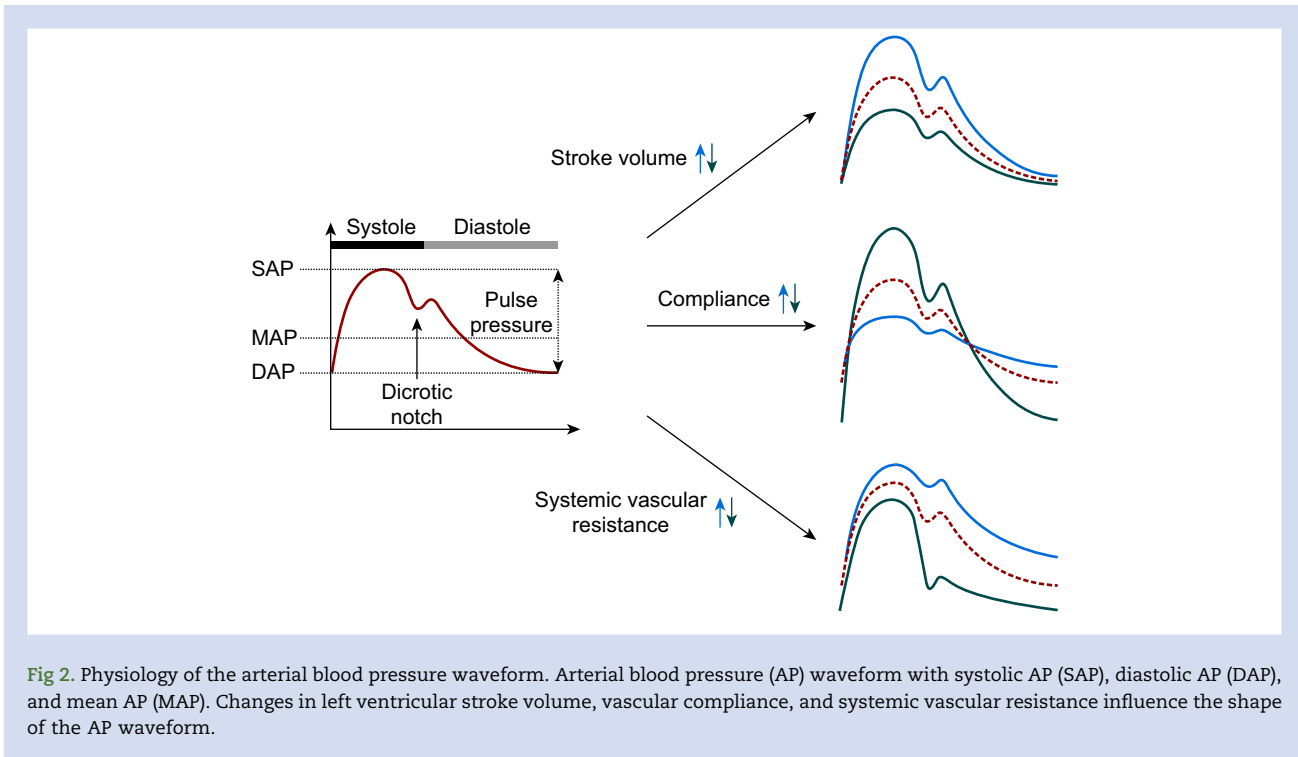

Fig 2. Physiology of the arterial blood pressure waveform. Arterial blood pressure (AP) waveform with systolic AP (SAP), diastolic AP (DAP), and mean AP (MAP). Changes in left ventricular stroke volume, vascular compliance, and systemic vascular resistance influence the shape of the AP waveform.

act like a capacitor which is able to store electrical charge (i.e. blood) when there is a charging force (i.e. pressure difference). During diastole, when the aortic valve is closed, the pressure inside the elastic vessels decreases and the stored elastic energy is used to propel the stored blood towards more distal vessels. At this particular point of the cardiac cycle, the outflow of the aorta is higher than the inflow which equals zero (the heart is not pumping blood into the aorta). Frank²⁴ described those fundamental mechanisms of the arterial system with a two-element Windkessel model. This model comprises a resistor R and a capacitor C and operates like an RC circuit (Fig. 3). According to Poiseuille's law, the resistance of the vascular system is mainly determined by resistance vessels (i.e. the smallest arteries and arterioles). The compliance is mainly determined by the elasticity of the aorta and other large arteries. However, a strict separation of compliant and resistance vessels of the arterial system is impossible because large compliant arteries also have resistive properties and small arteries and arterioles do have some compliance.²⁵ Therefore, these lumped arterial models are called Windkessel models, even though mainly the large arteries act as the Windkessel.

Assuming a RC circuit, CO can be calculated after identifying the time constant τ ($\tau = R \cdot C$) of the aortic pressure profile during diastole and estimating C from aortic pulse wave velocity and cross-sectional area. Even if the two-element Windkessel model can explain the exponential decay of proximal aortic pressure during diastole, it fails when explaining the systolic part of the AP waveform.²⁶ To further improve the two-element Windkessel model, more elements or wave reflection effects have been added over time to the initial model.

Three-element Windkessel

Ohm's law could only be applied, if blood vessels were rigid tubes. This would imply that the vascular resistance and the driving pressure over the whole cardiac cycle would be constant. However, the vascular system does not match these criteria as it comprises an elastic component with the consequence that the vascular resistance and flow vary with pressure over time. Therefore, three-element Windkessel models consider an additional variable, called impedance. The impedance depends on the classical resistance, the compliance, and the inertial properties of the vessels and the blood. For sinusoidal signals it refers to the relation between the pressure difference and the flow through a linear system.

The possibility of measuring aortic flow together with the ability to analyse this sinusoidal signal by carrying out Fourier analysis allowed the calculation of arterial input impedance. The arterial input impedance is the impedance of the whole system at its entrance. Westerhof and colleagues²⁷ added this resistive element, called the characteristic impedance Z_c in series with the RC model of the two-element Windkessel model (Fig. 3). This three-element Windkessel model is capable of simulating the behaviour of the arterial tree for low and high wave frequencies compared with the two-element Windkessel model that failed representing arterial properties at higher frequencies. By that, the model has been improved especially at higher frequencies.

Four-element Windkessel

The three-element Windkessel generally overestimates total arterial compliance and underestimates aortic characteristic

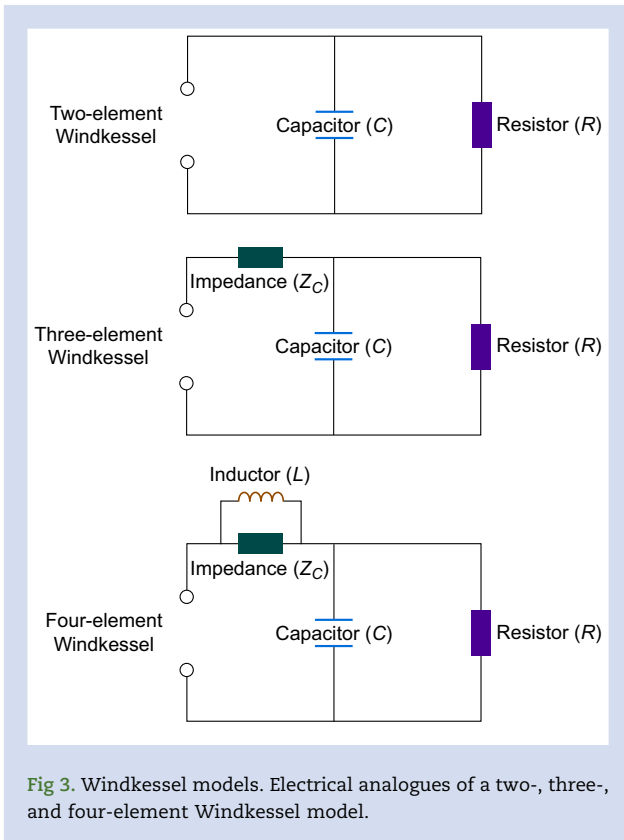

Fig 3. Windkessel models. Electrical analogues of a two-, three-, and four-element Windkessel model.

impedance; thus, a four-element Windkessel model was suggested.^{28,29} The fourth element introduced in the model is an inductor L which accounts for total arterial inertance (Fig. 3).³⁰ Arterial inertance combines the three variables blood density, vessel cross-sectional area, and vessel length. Using the four-element Windkessel model enables estimating total arterial compliance but estimating the inertance is difficult.

Wave reflection and Windkessel models

A major challenge for PWA using Windkessel models is that, in clinical practice, AP waveforms are usually obtained in a peripheral and not a central artery. Analysing the peripheral AP waveform is complex because of wave reflection phenomena²² that occur especially at the level of resistance arteries in the periphery.²¹ The waves are—in part—reflected backwards to the heart and interfere with each other. Pressure or flow measured distal to the central arteries are the result of forward- and backward-travelling waves. In this way, the AP waveform is increasingly altered by wave reflection phenomena with increasing distance from the heart³¹ and the exponential diastolic decay becomes less apparent in peripheral arteries. Windkessel models only simulate the behaviour of the arterial system at the entrance of the system but not in the periphery, because they do not take wave travel and wave reflection aspects into account. Besides, even in the human aorta there is no pure exponential decay of the diastolic part of the AP waveform.³²

The Modelflow technique and Hemac method

Wesseling and colleagues³³ used the three-element Windkessel model to compute blood flow from the AP waveform, called the Modelflow technique, determined aortic characteristic impedance and compliance based on patient data, and predicted peripheral resistance by fitting MAP data to the model. Because the compliance and the characteristic aortic impedance are a function of AP, the model behaviour is non-linear and therefore model computations are repeated for each new AP sample taken. Using this algorithm, they computed aortic flow using AP as input. Left ventricular SV is then calculated by integrating model flow during systole; CO is computed by multiplying SV with heart rate. However, the cross-sectional area of the aorta varies among patients and may deviate substantially from Langewouter and colleagues³⁴ study population average in individual patients.³⁵ Therefore, the Modelflow technique is calibrated against thermodilution to derive absolute CO values.^{33,35,36} A modified version of the Modelflow technique, the Hemac method, uses *in vivo* aortic cross-sectional area measurements of patients.³⁵ Calibration with thermodilution improves the absolute accuracy of the Hemac method.³⁵

Long time interval analysis technique

The 'long time interval analysis technique' aims to avoid the problem of confounding AP wave reflections.³⁷ The technique is based on the assumption that confounding wave reflection effects diminish with increasing time scale (so-called transmission line theory).³⁸ When observing and comparing the AP waveform in a short time scale, one can directly observe differences between the central and the peripheral pressure waveform.

When observing the AP waveform at long time scales, the arterial system acts as a single blood reservoir and the Windkessel model can thus be used to estimate CO.³⁷ Based on this theory, a technique was developed to mathematically analyse peripheral AP waveform intervals lasting several minutes and estimate the AP response to a single cardiac contraction (simulating that pulsatile activity abruptly ceased). An exponential is fitted to the tail end of this AP response to calculate the time constant that is proportional to CO.³⁷

A further development of this method is the so-called multi-beat analysis (MBA).^{37,39} MBA estimates CO continuously by analysing the AP waveform over time scales that include multiple heart beats and estimates a theoretical AP waveform that would be the response to a single isolated cardiac contraction.^{40,41}

Pulse power analysis

The pulse power analysis does not use the morphology of the AP waveform to estimate CO.⁴² It rather translates the original AP signal into a standardised volume waveform (volume in arbitrary units) based on the assumption that arterial compliance changes as AP changes. This relationship can be plotted approximately by an exponential⁴³ which is then used to calculate the volume change based on the pressure waveform with autocorrelation. Autocorrelation is a mathematical function that can be used to find and analyse repeating

patterns, such as the presence of a periodic signal.⁴⁴ Using the root mean square method finally derives the nominal SV that is scaled and calibrated to the actual SV that is ejected into the aorta.⁴⁵ In theory, the pulse power algorithm has several advantages over other PWA systems, such as measurement site independency and a reduced effect of damping to the system.⁴²

Pressure recording analytical method

The pressure recording analytical method (PRAM) analyses the AP waveform over the whole cardiac cycle and identifies specific parts of the AP waveform that only last for a few milliseconds, called 'points of instability'.⁴⁶ Therefore, an analytical resolution of 1000 points per second (1000 Hz) is necessary. Points of instability are distributed along the whole AP waveform and are mainly caused by the mix-up of forward and backward reflected waves.⁴⁷ The algorithm estimates cardiovascular impedance in a beat-to-beat resolution and allows the system to adapt for changes in vascular impedance as a result of changes in vascular tone, cardiac contractility, or heart rate.⁴⁸ This is why PRAM does not need external or internal (based on databases) calibrations in contrast to all other PWA techniques.⁴⁷ For the application of the PRAM algorithm, it is not only essential that the AP waveform is totally free of artifacts—which is true for basically every PWA method—but also that the damping properties of the arterial catheter/tubing/transducer-system are optimised.

Pulse wave analysis technologies available for clinical practice

Numerous monitoring systems using PWA are commercially available to be used at the bedside. These PWA monitoring systems can be classified according to their invasiveness and method to calibrate the estimated CO values (Fig. 4). There are invasive, minimally-invasive, and noninvasive PWA systems. PWA systems can additionally be classified according to their type of calibration into: (1) externally calibrated systems, (2) internally calibrated systems, and (3) uncalibrated systems. Externally calibrated systems combine PWA with another measurement technique—usually an indicator dilution method—to mandatorily calibrate PWA-derived CO values to CO values measured or estimated using the external measurement technique. Internally calibrated systems use biometric, demographic, and haemodynamic data, and AP waveform characteristics to calibrate PWA-derived CO values. Uncalibrated systems do not use external or internal calibration but estimate CO solely based on AP waveform characteristics.

Invasive and minimally-invasive pulse wave analysis

Invasive and minimally-invasive PWA technologies all have in common that they analyse an AP waveform that is invasively derived using an arterial catheter.

Invasive PWA with external calibration

Externally calibrated PWA systems estimate CO from the invasively assessed AP waveform and calibrate it to CO measurements from a reference method.

The PiCCO system (Pulsion Medical Systems, Feldkirchen, Germany) continuously estimates CO using PWA based on the area of the systolic part of the AP curve (until the diastolic notch indicating aortic valve closure). CO estimations are calibrated to CO measurements using intermittent transpulmonary thermodilution. Therefore, a central venous catheter (used for the injection of the cold indicator solution) and a dedicated thermistor-tipped arterial catheter (Pulsioath; Pulsion Medical Systems) are required. The arterial catheter should be placed in a central artery (femoral, brachial, or axillary artery). Periodic recalibration of the PWA-derived CO estimation by transpulmonary thermodilution is recommended,⁴⁹ particularly after anticipated changes in vascular tone, such as in patients with circulatory shock who require therapy with vasoactive agents⁵⁰ or larger amounts of fluids.⁵¹

Another commercially available monitoring system that calibrates PWA-derived CO to CO measured using intermittent transpulmonary thermodilution is the VolumeView system (Edwards Lifesciences, Irvine, CA, USA). It also requires a specific thermistor-tipped femoral arterial catheter (VolumeView catheter, Edwards Lifesciences) that is connected to a haemodynamic monitor (EV1000 or Hemosphere, both Edwards Lifesciences) and a central venous catheter for injection of cold indicator solution. The underlying PWA algorithm considers waveform characteristics based on a three-element Windkessel model and advanced wave shape parameters that primarily rely on the assessment of aortic compliance, waveform skewness, and kurtosis calculations.⁵²

The LiDCOplus system (LiDCO, Cambridge, UK) uses a proprietary algorithm (PulseCO) to estimate CO using pulse power analysis. The estimated CO is calibrated to CO measurements using intermittent transpulmonary lithium dilution. A specific lithium-sensitive electrode incorporated in an arterial catheter derives a lithium concentration-time curve. The area under this curve is inversely correlated to CO.⁵³ In patients on lithium therapy, lithium dilution-derived CO will be overestimated. In addition, use of some neuromuscular blocking agents containing quaternary ammonium residues may be detected by the lithium sensor, making CO calibration inaccurate.⁵⁴

Minimally-invasive PWA with internal calibration

Internally calibrated PWA systems estimate CO from the invasively obtained AP waveform without calibration to an external CO measurement. Thus, they do not require a (central) venous catheter for calibration and therefore are also referred to as 'minimally-invasive' PWA systems.⁷ Some internally calibrated systems additionally offer the option to alternatively—but not mandatorily—calibrate PWA-derived CO values to external CO values.

The FloTrac system (Edwards Lifesciences) is based on the so-called 'Arterial Pressure-based Cardiac Output' (APCO) algorithm. The APCO algorithm statistically analyses PP characteristics on a beat-to-beat basis and corrects it for changes in arterial compliance and resistance.^{55,56} In detail, the AP waveform is analysed at a high resolution, and the standard deviation of successive PP measurements is calculated. Vascular tone is estimated based on MAP and AP waveform characteristics such as skewness and kurtosis. All these variables are combined into a factor 'Chi' that is continuously updated and used for CO estimation.⁵⁵

The ProAQ/Pulsioflex system (Pulsion Medical Systems) continuously estimates CO based on the area of the systolic

part of the AP curve. It corrects for aortic compliance purely based on empiric demographic and biometric data.

The LiDGOrapid system (LiDGO) uses pulse power analysis and the proprietary PulseCO algorithm to estimate CO without external calibration by lithium dilution. A nomogram is used to estimate CO from the nominal maximum aortic volume. The nomogram results from multivariate analysis of the relation between aortic volume and biometric and demographic data.⁵⁷

The Argos CO monitor (Retia Medical, Valhalla, NY, USA) uses MBA to estimate CO. Its measurement principle is based on long time interval analysis and applies a scaling formula which uses biometric data for CO estimation.^{40,41}

Minimally-invasive uncalibrated PWA

The MostCare system (Vygon, Écouen, France) is an uncalibrated PWA system. It is based on the PRAM algorithm that allows beat-to-beat impedance estimations and further calculation of haemodynamic variables such as SV or CO. The ability to update the impedance during each heartbeat makes the system reactive in case of sudden cardiovascular changes (e.g. changes in vascular tone, volume expansion, activation or depression of the sympathetic nervous system). The MostCare system is connected to an arterial pressure transducer or another monitor that obtains a continuous AP waveform.

Noninvasive pulse wave analysis

In the past years, several methods for noninvasive PWA using noninvasive sensors to continuously record the AP waveform became available.^{6,58,59} In contrast to invasive and minimally-invasive PWA methods, noninvasive PWA methods do not bear the effort and risks associated with arterial or (central) venous cannulation. Noninvasive PWA systems are either based on the volume clamp method using a finger-cuff or on automated radial artery applanation tonometry using a sensor placed on the skin over the radial artery. All currently available noninvasive PWA systems use internal calibration to estimate CO.

Volume clamp method

The volume clamp method, also called vascular unloading technology or finger-cuff technology, was first described by Penáz and colleagues.⁶⁰ After technical and algorithmic refinements, this measurement principle is used by the ClearSight system (Edwards Lifesciences), formerly Nexfin (BMEye, Amsterdam, The Netherlands), and the CNAP system (CNSystems Medizintechnik, Graz, Austria). The sensor of volume clamp method-based systems contains an inflatable finger-cuff and an infrared plethysmograph that measures the blood volume in the finger arteries, which is changing during

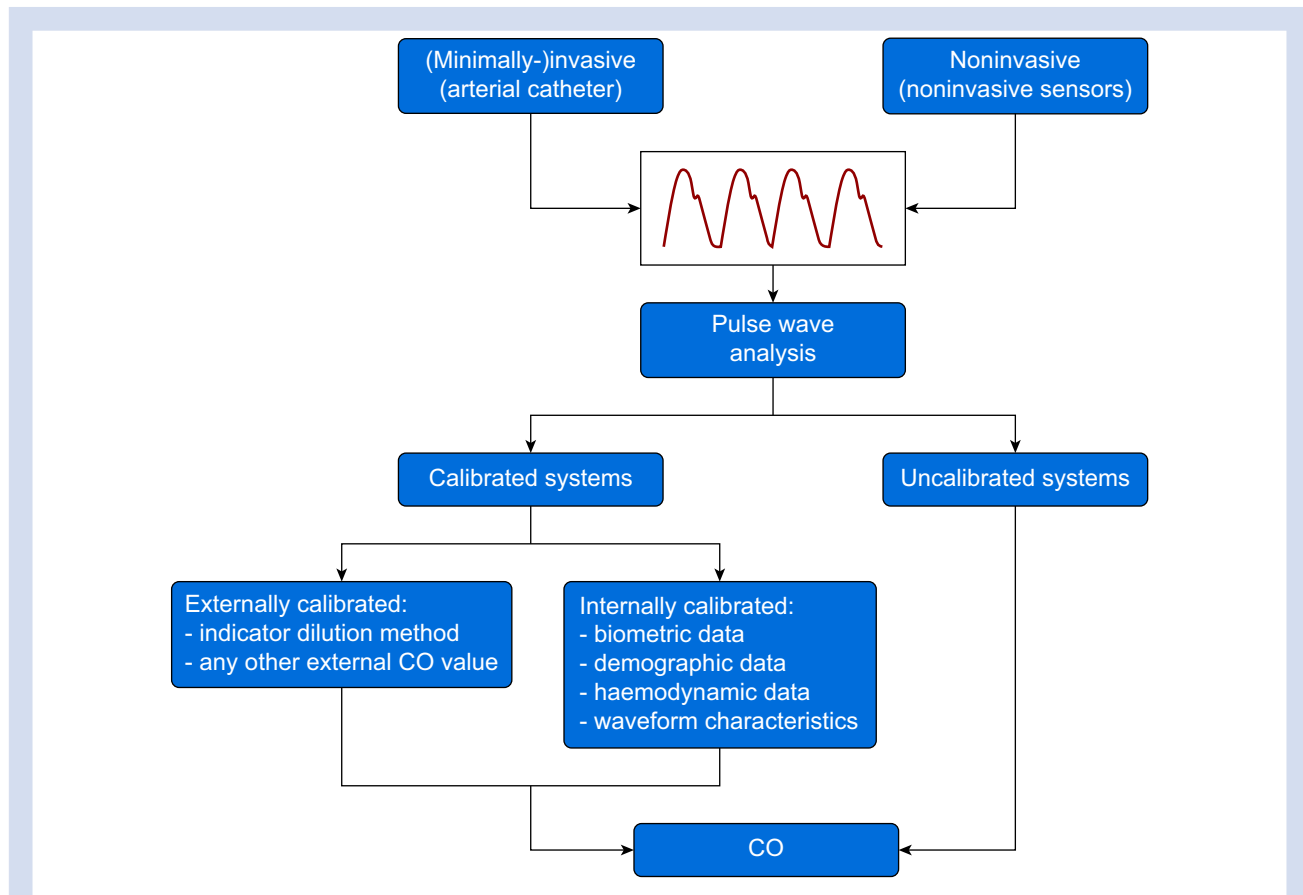

Fig 4. Classification of pulse wave analysis monitoring systems. Pulse wave analysis monitoring systems are classified according to their invasiveness and method they use to calibrate the estimated cardiac output (CO).

the cardiac cycle as a result of changes in AP.⁶¹ An automated feedback system inflates and deflates the finger-cuff rapidly in order to keep the volume in the finger arteries constant (unloaded) by applying a counter pressure. From this counter pressure, the AP waveform is reconstructed indirectly and is analysed using PWA to estimate CO. Since a proper pulsation in the finger arteries is mandatory for this technology, several clinical conditions such as circulatory shock, high-dose vasopressor therapy, hypothermia, and vascular diseases are limitations.⁶²

The ClearSight system uses one or two finger-cuffs and a heart reference sensor to compensate for hydrostatic pressure differences between the level of the heart and the finger-cuff. The ClearSight system internally calibrates the AP waveform continuously to compensate for vasodilation and vasoconstriction.^{61,63} The subsequently displayed AP waveform is scaled and adapted to resemble brachial AP.^{64,65} Assuming a three-element Windkessel model, the AP waveform is analysed using PWA to estimate CO.⁶⁶

The CNAP system uses an alternating double finger-cuff and scales the obtained AP waveform to intermittent oscillometric upper-arm cuff AP values and thereby resembles brachial AP. The underlying PWA algorithm of the CNAP system is called continuous noninvasive CO (CNCO) algorithm.⁶⁷ The CNCO algorithm estimates CO by analysing the systolic and diastolic part of the AP waveform, thereby accounting for preload, contractility, afterload, and vessel compliance.⁶⁷ Database-derived calibration factors are used to obtain absolute CO values.

Applanation tonometry

Another method for CO estimation using noninvasive PWA is automated radial artery applanation tonometry.^{6,58,59,62,68} To continuously record the AP waveform, a sensor is placed on the skin above the radial artery. It slightly compresses (i.e. applanates) the radial artery so that its transmural pressure is zero. At this point of zero transmural pressure, MAP can be measured. After scaling of the waveform, the system displays the AP waveform and analyses it using PWA. Different approaches have been proposed to adjust the sensor. The T-Line system (Shanshi Medical, Shangqiu, China; formerly, Tensys Medical, San Diego, CA, USA) uses a sensor included in a bracelet that electromechanically adjusts sensor position.⁶⁸ The DMP-Life system (DAEYOMEDI Co., Ansan, South Korea) uses an array of piezoresistive semiconductor transducer sensors adjusted by an actuator.⁶⁹

The T-Line system estimates CO using PWA with a non-linear mathematical model comprising biometric and demographic data and AP waveform characteristics (SAP, DAP, MAP, PP, beat-to-beat interval, maximal slope within systole, and systolic area).⁷⁰

The DMP-Life system estimates CO using a modified Kouchouk algorithm⁷¹ analysing the systolic part of the AP waveform and considering biometric and demographic data.⁶⁹

Systems for automated applanation tonometry are susceptible to motion artifacts. Even slight movements of the sensor can impair the AP waveform quality and falsify SV and CO estimations.

General limitations of pulse wave analysis

Besides inherent technical limitations of each PWA technology, PWA has some method immanent general limitations that need to be considered. PWA depends on an optimal AP waveform signal that can be disturbed in certain clinical situations.⁶

Although invasive AP monitoring with an arterial catheter is the reference method to record the AP waveform, measurements can be invalidated by artifacts, including underdamping and overdamping.^{72,73} Underdamping and especially overdamping may lead to the impossibility to correctly perform PWA, since many PWA algorithms rely on the correct identification of the dicrotic notch that is necessary to distinguish the systolic and the diastolic parts of the AP waveform. Most PWA devices do not automatically detect and correct inappropriate AP waveform readings. Therefore, the operator needs to visually check, and if necessary correct the AP waveform regularly. Thus fast-flush tests should repeatedly be performed because the dynamic response may change over time.⁷⁴ PWA-derived variables should only be used after the AP waveform has been checked for artifacts and has been optimised.

Arterial compliance has a major impact on PWA-derived CO estimations. Age influences arterial compliance. Although most systems account for the effect of age on arterial compliance in the underlying algorithm, most algorithms have not been validated in paediatric patients.

Rapid changes and alterations in vasomotor tone that occur, for instance, in patients having septic shock and liver failure, may impair the measurement performance of PWA systems. Invasive externally calibrated PWA systems should be frequently re-calibrated in these patients.⁴⁹ Minimally-invasive and noninvasive PWA systems may require some time to adapt to the new haemodynamic situation; new CO estimations may nevertheless deviate from the true value.

PWA cannot be used in patients with non-pulsatile blood flow (e.g. patients on veno-arterial extracorporeal membrane oxygenation or patients with a left ventricular assist device). Of note, veno-venous extracorporeal membrane oxygenation does not alter the AP waveform but may impact thermodilution CO measurements⁷⁵ used by invasive externally calibrated PWA systems.

Conclusions

Cardiac output is a key determinant of oxygen delivery. Pulse wave analysis allows the estimation of cardiac output based on a continuous analysis of the AP waveform. A profound understanding of the physiology of the arterial pressure waveform, basic principles of pulse wave analysis algorithms for cardiac output estimation, and limitations of pulse wave analysis technologies is key when using pulse wave analysis in clinical practice. The arterial pressure waveform is a complex physiological signal that is determined by an interplay of left ventricular stroke volume, systemic vascular resistance, and vascular compliance. There are numerous pulse wave analysis algorithms to estimate cardiac output, including Windkessel models, long time interval analysis or multi-beat analysis,

pulse power analysis, or pressure recording analytical method. There are invasive, minimally-invasive, and noninvasive pulse wave analysis monitoring systems that can additionally be classified according to the method they use to calibrate the estimated cardiac output values in externally calibrated systems, internally calibrated systems, and uncalibrated systems.

Authors' contributions

Conception of the review: BS, KK, DDB

Literature search, writing of the manuscript: all authors

Declarations of interest

BS has received honoraria for consulting, honoraria for giving lectures, and refunds of travel expenses from Edwards Lifesciences (Irvine, CA, USA). BS has received honoraria for consulting, institutional restricted research grants, honoraria for giving lectures, and refunds of travel expenses from Pulsion Medical Systems (Feldkirchen, Germany). BS has received institutional restricted research grants, honoraria for giving lectures, and refunds of travel expenses from CNSystems Medizintechnik (Graz, Austria). BS has received institutional restricted research grants from Retia Medical (Valhalla, NY, USA). BS has received honoraria for giving lectures from Philips Medizin Systeme Böblingen (Böblingen, Germany). BS has received honoraria for consulting, institutional restricted research grants, and refunds of travel expenses from Tensys Medical (San Diego, CA, USA). TWLS received research grants and honoraria for consulting and lecturing from Edwards Lifesciences and Masimo (Irvine, CA, USA) and honoraria for lecturing from Pulsion Medical Systems. SR has received honoraria and consultation fees from Vygon (Ecouen, France), Masimo, MSD (Kenilworth, NJ, USA), Medigas (Assago, Italy), Baxter (Rome, Italy), BBraun (Melsungen, Germany), Orion Pharma (Espoo, Finland), and Medtronic (Minneapolis, MN, USA). DDB has received honoraria for consulting from Edwards Lifesciences. The other authors declare that they have no conflicts of interest.

References

- Saugel B, Vincent J-L, Wagner JY. Personalized hemodynamic management. *Curr Opin Crit Care* 2017; 23: 334–41
- Chong MA, Wang Y, Berbenetz NM, McConachie I. Does goal-directed haemodynamic and fluid therapy improve peri-operative outcomes?: a systematic review and meta-analysis. *Eur J Anaesthesiol* 2018; 35: 469–83
- Michard F, Giglio MT, Brienza N. Perioperative goal-directed therapy with uncalibrated pulse contour methods: impact on fluid management and postoperative outcome. *Br J Anaesth* 2017; 119: 22–30
- Vincent JL, Rhodes A, Perel A, et al. Clinical review: update on hemodynamic monitoring—a consensus of 16. *Crit Care* 2011; 15: 229
- Cecconi M, De Backer D, Antonelli M, et al. Consensus on circulatory shock and hemodynamic monitoring. Task force of the European Society of Intensive Care Medicine. *Intensive Care Med* 2014; 40: 1795–815
- Teboul J-L, Saugel B, Cecconi M, et al. Less invasive hemodynamic monitoring in critically ill patients. *Intensive Care Med* 2016; 42: 1350–9
- Saugel B, Vincent JL. Cardiac output monitoring: how to choose the optimal method for the individual patient. *Curr Opin Crit Care* 2018; 24: 165–72
- De Backer D, Bakker J, Cecconi M, et al. Alternatives to the Swan-Ganz catheter. *Intensive Care Med* 2018; 44: 730–41
- Saugel B, Reuter DA. Perioperative goal-directed therapy using invasive uncalibrated pulse contour analysis. *Front Med (Lausanne)* 2018; 5: 12
- Kouz K, Scheeren TW, De Backer D, Saugel B. Pulse wave analysis to estimate cardiac output. *Anesth Adv* 2020. <https://doi.org/10.1097/ALN.0000000000003553>. Access published on September 10, 2020
- Pearse RM, Harrison DA, MacDonald N, et al. Effect of a perioperative, cardiac output-guided hemodynamic therapy algorithm on outcomes following major gastrointestinal surgery: a randomized clinical trial and systematic review. *JAMA* 2014; 311: 2181–90
- Funcke S, Saugel B, Koch C, et al. Individualized, perioperative, hemodynamic goal-directed therapy in major abdominal surgery (iPEGASUS trial): study protocol for a randomized controlled trial. *Trials* 2018; 19: 273
- Salzwedel C, Puig J, Carstens A, et al. Perioperative goal-directed hemodynamic therapy based on radial arterial pulse pressure variation and continuous cardiac index trending reduces postoperative complications after major abdominal surgery: a multi-center, prospective, randomized study. *Crit Care* 2013; 17: R191
- Monnet X, Teboul JL. Passive leg raising: five rules, not a drop of fluid! *Crit Care* 2015; 19: 18
- Cecconi M, Parsons AK, Rhodes A. What is a fluid challenge? *Curr Opin Crit Care* 2011; 17: 290–5
- Mayet J, Hughes A. Cardiac and vascular pathophysiology in hypertension. *Heart* 2003; 89: 1104–9
- Wiggers CJ, Katz LN. The contour of the ventricular volume curves under different conditions. *Am J Physiol* 1922; 58: 439–75
- Razminia M, Trivedi A, Molnar J, et al. Validation of a new formula for mean arterial pressure calculation: the new formula is superior to the standard formula. *Catheter Cardiovasc Interv* 2004; 63: 419–25
- Bayliss WM. On the local reactions of the arterial wall to changes of internal pressure. *J Physiol* 1902; 28: 220–31
- Hall JE. *Guyton and Hall Textbook of medical physiology*. 13th Edn. Philadelphia: Elsevier; 2016
- Mitchell GF. Effects of central arterial aging on the structure and function of the peripheral vasculature: implications for end-organ damage. *J Appl Physiol* 2008; 105: 1652–60 (1985)
- Latham RD, Westerhof N, Sipkema P, Rubal BJ, Reuderink P, Murgo JP. Regional wave travel and reflections along the human aorta: a study with six simultaneous micromanometric pressures. *Circulation* 1985; 72: 1257–69
- Kelly R, Hayward C, Avolio A, O'Rourke M. Noninvasive determination of age-related changes in the human arterial pulse. *Circulation* 1989; 80: 1652–9
- Frank O. Die Grundform des arteriellen Pulses. *Z Biol* 1899; 37: 483–526
- Westerhof N, Lankhaar JW, Westerhof BE. The arterial Windkessel. *Med Biol Eng Comput* 2009; 47: 131–41
- Wetterer E. Quantitative Beziehungen zwischen Stromstärke und Druck im natürlichen Kreislauf bei

- zeitlich variabler Elastizität des arteriellen Windkessels. *Z Biol* 1940; **100**: 260–317
27. Westerhof N, Elzinga G, Sipkema P. An artificial arterial system for pumping hearts. *J Appl Physiol* 1971; **31**: 776–81
 28. Segers P, Brimiouille S, Stergiopoulos N, et al. Pulmonary arterial compliance in dogs and pigs: the three-element windkessel model revisited. *Am J Physiol* 1999; **277**: H725–31
 29. Stergiopoulos N, Meister JJ, Westerhof N. Evaluation of methods for estimation of total arterial compliance. *Am J Physiol* 1995; **268**: H1540–8
 30. Stergiopoulos N, Westerhof BE, Westerhof N. Total arterial inertance as the fourth element of the windkessel model. *Am J Physiol* 1999; **276**: H81–8
 31. O'Rourke MF, Yaginuma T. Wave reflections and the arterial pulse. *Arch Intern Med* 1984; **144**: 366–71
 32. Cundick Jr RM, Gardner RM. Clinical comparison of pressure-pulse and indicator-dilution cardiac output determination. *Circulation* 1980; **62**: 371–6
 33. Wesseling KH. Computation of aortic flow from pressure in humans using a nonlinear, three-element model. *J Appl Physiol* 1993; **74**: 2566–73 (1985)
 34. Langewouters GJ, Wesseling KH, Goedhard WJ. The pressure dependent dynamic elasticity of 35 thoracic and 16 abdominal human aortas in vitro described by a five component model. *J Biomech* 1985; **18**: 613–20
 35. de Wilde RB, Schreuder JJ, van den Berg PC, Jansen JR. An evaluation of cardiac output by five arterial pulse contour techniques during cardiac surgery. *Anaesthesia* 2007; **62**: 760–8
 36. Jansen JR, Schreuder JJ, Mulier JP, Smith NT, Settels JJ, Wesseling KH. A comparison of cardiac output derived from the arterial pressure wave against thermodilution in cardiac surgery patients. *Br J Anaesth* 2001; **87**: 212–22
 37. Mukkamala R, Reisner AT, Hojman HM, Mark RG, Cohen RJ. Continuous cardiac output monitoring by peripheral blood pressure waveform analysis. *IEEE Trans Biomed Eng* 2006; **53**: 459–67
 38. Noordergraaf A. *Circulatory system dynamics*. New York: Academic Press; 1978
 39. Lu Z, Mukkamala R. Continuous cardiac output monitoring in humans by invasive and noninvasive peripheral blood pressure waveform analysis. *J Appl Physiol* 2006; **101**: 598–608 (1985)
 40. Saugel B, Heeschen J, Hapfelmeier A, Romagnoli S, Greiwe G. Cardiac output estimation using multi-beat analysis of the radial arterial blood pressure waveform: a method comparison study in patients having off-pump coronary artery bypass surgery using intermittent pulmonary artery thermodilution as the reference method. *J Clin Monit Comput* 2020; **34**: 649–54
 41. Greiwe G, Peters V, Hapfelmeier A, Romagnoli S, Kubik M, Saugel B. Cardiac output estimation by multi-beat analysis of the radial arterial blood pressure waveform versus intermittent pulmonary artery thermodilution: a method comparison study in patients treated in the intensive care unit after off-pump coronary artery bypass surgery. *J Clin Monit Comput* 2019; **34**: 643–8
 42. Pinsky MR, Payen D. *Functional hemodynamic monitoring*. Berlin; New York: Springer; 2006
 43. Jonas MM, Tanser SJ. Lithium dilution measurement of cardiac output and arterial pulse waveform analysis: an indicator dilution calibrated beat-by-beat system for continuous estimation of cardiac output. *Curr Opin Crit Care* 2002; **8**: 257–61
 44. Vincent JL. *Intensive care medicine. Annual update 2008*. New York: Springer; 2008
 45. Montenijs LJ, de Waal EE, Buhre WF. Arterial waveform analysis in anesthesia and critical care. *Curr Opin Anaesthesiol* 2011; **24**: 651–6
 46. Romano SM, Pistolesi M. Assessment of cardiac output from systemic arterial pressure in humans. *Crit Care Med* 2002; **30**: 1834–41
 47. Romagnoli S, Franchi F, Ricci Z, Scolletta S, Payen D. The pressure recording analytical method (PRAM): technical concepts and literature review. *J Cardiothorac Vasc Anesth* 2017; **31**: 1460–70
 48. Vincent JL, Pelosi P, Pearse R, et al. Perioperative cardiovascular monitoring of high-risk patients: a consensus of 12. *Crit Care* 2015; **19**: 224
 49. Hamzaoui O, Monnet X, Richard C, Osman D, Chemla D, Teboul JL. Effects of changes in vascular tone on the agreement between pulse contour and transpulmonary thermodilution cardiac output measurements within an up to 6-hour calibration-free period. *Crit Care Med* 2008; **36**: 434–40
 50. Yamashita K, Nishiyama T, Yokoyama T, Abe H, Manabe M. The effects of vasodilation on cardiac output measured by PiCCO. *J Cardiothorac Vasc Anesth* 2008; **22**: 688–92
 51. Wiesenack C, Fiegl C, Keyser A, Prasser C, Keyl C. Assessment of fluid responsiveness in mechanically ventilated cardiac surgical patients. *Eur J Anaesthesiol* 2005; **22**: 658–65
 52. Bendjelid K, Marx G, Kiefer N, et al. Performance of a new pulse contour method for continuous cardiac output monitoring: validation in critically ill patients. *Br J Anaesth* 2013; **111**: 573–9
 53. Kurita T, Morita K, Kato S, Kikura M, Horie M, Ikeda K. Comparison of the accuracy of the lithium dilution technique with the thermodilution technique for measurement of cardiac output. *Br J Anaesth* 1997; **79**: 770–5
 54. Mehta N, Fernandez-Bustamante A, Seres T. A review of intraoperative goal-directed therapy using arterial waveform analysis for assessment of cardiac output. *Sci World J* 2014; **2014**: 702964
 55. Pratt B, Roteliuk L, Hatib F, Frazier J, Wallen RD. Calculating arterial pressure-based cardiac output using a novel measurement and analysis method. *Biomed Instrum Technol* 2007; **41**: 403–11
 56. De Backer D, Marx G, Tan A, et al. Arterial pressure-based cardiac output monitoring: a multicenter validation of the third-generation software in septic patients. *Intensive Care Med* 2011; **37**: 233–40
 57. Costa MG, Chiarandini P, Scudeller L, et al. Uncalibrated continuous cardiac output measurement in liver transplant patients: LiDCOrapid system versus pulmonary artery catheter. *J Cardiothorac Vasc Anesth* 2014; **28**: 540–6
 58. Saugel B, Cecconi M, Wagner JY, Reuter DA. Noninvasive continuous cardiac output monitoring in perioperative and intensive care medicine. *Br J Anaesth* 2015; **114**: 562–75
 59. Saugel B, Cecconi M, Hajjar LA. Noninvasive cardiac output monitoring in cardiothoracic surgery patients: available methods and future directions. *J Cardiothorac Vasc Anesth* 2019; **33**: 1742–52

60. Penáz J, Voigt A, Teichmann W. Contribution to the continuous indirect blood pressure measurement. *Z Gesamte Inn Med* 1976; **31**: 1030–3
61. Imholz BP, Wieling W, van Montfrans GA, Wesseling KH. Fifteen years experience with finger arterial pressure monitoring: assessment of the technology. *Cardiovasc Res* 1998; **38**: 605–16
62. Saugel B, Dueck R, Wagner JY. Measurement of blood pressure. *Best Pract Res Clin Anaesthesiol* 2014; **28**: 309–22
63. Wesseling K. Physiological, calibrating finger vascular physiology for Finapres. *Homeostasis* 1995; **36**: 67–82
64. Gizdulich P, Prentza A, Wesseling KH. Models of brachial to finger pulse wave distortion and pressure decrement. *Cardiovasc Res* 1997; **33**: 698–705
65. Martina JR, Westerhof BE, van Goudoever J, et al. Noninvasive continuous arterial blood pressure monitoring with Nexfin®. *Anesthesiology* 2012; **116**: 1092–103
66. Truijen J, van Lieshout JJ, Wesseling WA, Westerhof BE. Noninvasive continuous hemodynamic monitoring. *J Clin Monit Comput* 2012; **26**: 267–78
67. Wagner JY, Grond J, Fortin J, Negulescu I, Schöfthaler M, Saugel B. Continuous noninvasive cardiac output determination using the CNAP system: evaluation of a cardiac output algorithm for the analysis of volume clamp method-derived pulse contour. *J Clin Monit Comput* 2016; **30**: 487–93
68. Dueck R, Goedje O, Clopton P. Noninvasive continuous beat-to-beat radial artery pressure via TL-200 applanation tonometry. *J Clin Monit Comput* 2012; **26**: 75–83
69. Zayat R, Goetzenich A, Lee JY, et al. Comparison between radial artery tonometry pulse analyzer and pulsed-Doppler echocardiography derived hemodynamic parameters in cardiac surgery patients: a pilot study. *Peer J* 2017; **5**: e4132
70. Saugel B, Meidert AS, Langwieser N, et al. An autocalibrating algorithm for non-invasive cardiac output determination based on the analysis of an arterial pressure waveform recorded with radial artery applanation tonometry: a proof of concept pilot analysis. *J Clin Monit Comput* 2014; **28**: 357–62
71. Kouchoukos NT, Sheppard LC, McDonald DA. Estimation of stroke volume in the dog by a pulse contour method. *Circ Res* 1970; **26**: 611–23
72. Romagnoli S, Ricci Z, Quattrone D, et al. Accuracy of invasive arterial pressure monitoring in cardiovascular patients: an observational study. *Crit Care* 2014; **18**: 644
73. Saugel B, Kouz K, Meidert AS, Schulte-Uentrop L, Romagnoli S. How to measure blood pressure using an arterial catheter: a systematic 5-step approach. *Crit Care* 2020; **24**: 172
74. Gardner RM. Direct blood pressure measurement—dynamic response requirements. *Anesthesiology* 1981; **54**: 227–36
75. Reuter DA, Huang C, Edrich T, Shernan SK, Eltzschig HK. Cardiac output monitoring using indicator-dilution techniques: basics, limits, and perspectives. *Anesth Analg* 2010; **110**: 799–811

Handling editor: Jonathan Hardman